

HOLIDAY HOMEWORK

CLASS XII

SESSION 2024-25

ENGLISH PROJECT WORK

Work should be done in a project file properly covered, neatly decorated and covered with cellophane transparent sheet.

Your work should be assisted with concerned pictures from the internet.

Your work should have proper heading and sub headings .

Your work should be in the following sequence:

- Acknowledgement
- Index
- English Literature

Write on the given topics:

1. Analysis of the character Tarapada from the story ' Atithi' that you have studied.
2. Summary of the play 'Macbeth ' .
3. Critical analysis of any one poem of your syllabus.

- English Language
 1. Write a proposal from your English Language book.
 2. Write a Film review of a movie that you have recently watched
- Bibliography

PHYSICS

Dear students.

You are required to prepare physics project on any **one** of the following topics given below.

- **Capacitors and Dielectrics**
- **D.C Circuits and Measurements**
- **Magnetic Effect of Current and Magnetism**
- **Alternating Current**
- **Semiconductors**
- **Radioactivity**
- **Wave Optics**

Kindly follow the following instructions for preparing the project.

Use **A₄** size interleave sheets for writing the matter of the project.

Project is to be submitted in a drawing file/Project file which should be covered with the white paper and Cellophane.

On the cover page of the file you must write your name, class, section, roll number, session at the right hand bottom corner.

You must paste a coloured print out of the topic of the project with relevant picture on the cover page of the project.

Page limit of the project is **30 - 35 pages**.

Diagrams related to the topic of the project can either be handmade diagrams or the printout of the same.

Last date to submit the project is

8th July 2024.

CHEMISTRY

- Revise the subject matter done in the class.
- Complete your project work and practical file.

Biology

1. Complete your biology practical file.
2. Add 10-15 pages in your project file related to your given topic. For example if you've the topic of World Population you may add the measures to control it, current world population, reasons of population, etc.
3. Write one page summary of the chapter (given roll no. wise) and another page of the diagrams related to that chapter [Total 2 pages]. Write it and attach it to a milky file with the respective chapter name & your details (class, roll no) on the cover of the file.

COMMERCE

Topic 1: CAPITAL STRUCTURE: An Analysis

Pick any 1 company of any field. Find out, identify, analyse the capital structure of that company covering up certain points: Equity share, E.S.O.P, Sweat share, Bonus shares, fixed capital, working capital dentures, loans.

Topic 2: Marketing Strategy: A Report

Select any 2 companies listed on a stock exchange of India under various sectors (FMCG, Pharma., Automobile, Metal and minerals etc), analyse their sales, revenue, profit (2 quarter/year can be compared) and explain the marketing strategy used by these two different companies to boost their sales thereby reflecting :

- How they understood and captured taste and preference of consumers
- How they captured the market, leaving behind their competitors

Instructions for the project

1. The project will be of 36 pages in total (6+30)
 2. Minimum 30 pages for the content (not less than 15 in any topic)
 3. Plus 6 pages in the following criteria:
 - a. Acknowledgement (starting page)
 - b. Index (second page after acknowledgement
CONTENT of 15 pages (Topic 1)
 - c. Conclusion of Topic 1 (what all did you learn, understood while making the project)
CONTENT of 15 pages (Topic 2)
 - d. Conclusion of Topic 2 (what all did you learn, understood while making the project)
 - e. Bibliography (references from where project matter was taken)
 - f. Remarks (the page will be blank with only REMARKS written at the top)
- PROJECT FILE WILL BE HARD COVER FILE, PAGES TIED WITH A RIBBON
 - PROJECT FILE TO BE COVERED WITH LIGHT BLUE COLOURED PAPER 
 - Sample of the cover page will be provided (you can fill in your details and stick it on your cover page of the file)
 - Colour pictures or pens are NOT compulsory.
 - Last date for the submission is 20th JULY 2024 (without any sort of leverage)

Be creative.

ECONOMICS

TOPIC 1: BANKING

- History of Banking
- Types of Banks
- Functions of Banks
 - Accepts Deposits
 - Advances Loans
 - Credit Creation and Its Limitations
 - Types of cheques/drafts/banking instruments

- Structure of Banks in India
- Central Bank
 - Meaning
 - Functions
 - RBI (Office, Management)
 - How does Central Bank issue currency? (Minimum Reserve System)
- Make a comparative analysis of lending performance of five Commercial Banks in the past six years with reference to the changing CRR and SLR.
- Conclusion

PROJECT-2

AI Will Transform the Global Economy. Let's Make Sure It Benefits Humanity

- What will be the implications of recent developments in AI on global economic growth, as they mature over the upcoming decade?
- Advantages to the economy-Job changes
- Potential risk Challenges and Concerns
- New avenues
- conclusion

NOTE:

*Add pictures from magazines and internet.

*Submit it in thread file covered with white sheet.

*Pages should be arranged in the following order –

- Acknowledgement
- Index
- Topic 1
- Topic 2
- Bibliography
- Remarks

ACCOUNTS

*PRACTICE ALL THE PRACTICAL QUESTIONS FROM T.S GREWAL & D.K GOYAL OF FOLLOWING CHAPTERS:

- ACCOUNTING FOR PARTNERSHIP FIRM – FUNDAMENTALS
- GOODWILL: CONCEPT & VALUATION

MATHEMATICS

ASSIGNMENT -1

[For Science Students]

Section A Compulsory (any topic)

Any topic from Section B or C

[For Commerce Students]

Section A Compulsory (any topic)

Any topic from section C (compulsory)

[Minimum 30 Pages]

Front(cover page) – White cover, School logo, Name, Class, Roll no.

The following will be the structure of the assignment-

Acknowledgement

Index

Introduction

Topic

Content will be based on selected topics

Use coloured images according to the requirements

Conclusion

Bibliography

Remark

[THE LAST DATE FOR SUBMISSION IS 20th OF JULY]

Biotechnology

Write 2-3 case studies related to the topic you selected for project assessment. These pages will be attached in the project file.

It should not exceed 10 pages.

Pictures, diagrams and related material should be pasted on blank sides.

Computer Science

Q1 Do Question numbers 11 to 15 page 408 and 409 of your book Understanding ISC computer

Science (APC) in your classwork copy.

Q2 Write the output obtained after each gate in the following diagrams and finally write the final output

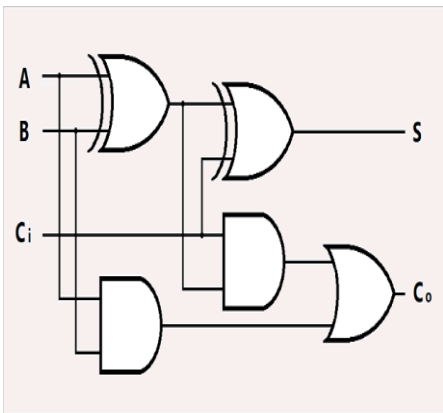
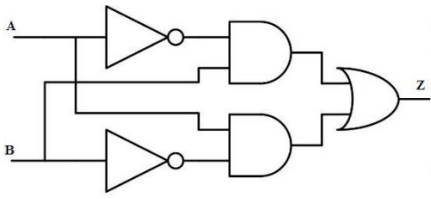
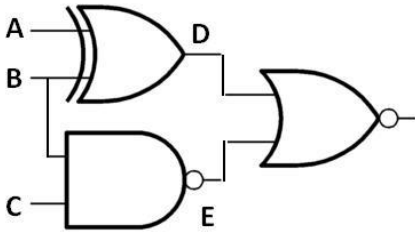

HINDI

परियोजना कार्य

- किसी भी विषय पर दो निबंध लिखने हैं (शब्द सीमा 400-450 शब्द)
- काव्य मंजरी में से पढ़ाई गई कविता के कवि का परिचय और भावार्थ लिखना है।
- आषाढ़ का एक दिन नाटक में से किसी भी मुख्य पात्र का चरित्र चित्रण लिखना है।

- गद्य संकलन में से पढ़ाई गई कहानी के लेखक का परिचय और उस कहानी का सारांश लिखना है।